

High Performance Digital FM Transmitter for Portable Devices

General Description

The QN8007 is a high performance, low power, full-featured single-chip stereo FM transmitter designed for portable audio/video players, automotive accessories, cell phones, and GPS personal navigation devices. It integrates transmitting functions, clear channel scan, and antenna tuning to ease matching in real applications. Advanced digital architecture enables variable input gain programmable; selectable pre-emphasis, precision low-spur MPX stereo encoding and pilot tone generation, low-noise PLL-based modulation, and an on-chip power amplifier with variable output level and RF band-pass filtering to ensure optimum transmit spectrum purity.

With its small footprint, minimal external component count and multiple clock frequency support, the QN8007 is easy to integrate into a variety of small form-factor low power portable applications. An integrated voltage regulator enables direct connection to a battery and provides high PSRR for superior noise suppression. A low-power Standby mode extends battery life. ESD protection is on all pins. The QN8007 is fabricated in highly reliable CMOS technology.

Key Features

- **Worldwide FM Band Transmit**
 - 76 MHz to 108 MHz full band tuning in 50/100/200 kHz step sizes
 - 50/75 μ s pre-emphasis
- **High Performance FM Transmitter (FMT)**
 - 66dB Stereo SNR, 0.03% THD
 - Maximum 121dB μ V RF output level with 42dB adjustable range
 - Integrated Clear Channel Scan
- **RDS/RBDS Transmit**
 - Supports US and European data service, including TMC (Traffic Messaging Channel) (not available in QN8007L)
- **Flexible Audio Interfaces**
 - Digital audio interface supports I²S and a variety of PCM data formats with 4 different data rates
 - Programmable analog audio input/output
 - Integrated audio AGC and soft clipping
- **Very Low Power Consumption**
 - 10.9 mA
 - Integrated voltage regulator, direct connect to battery
 - Power saving idle and standby modes
 - Low shutdown leakage current
- **Ease of Integration**
 - Small footprint, 4 x 4 x 0.85mm QFN24
 - Adaptive antenna tuning
 - Low cellular and GPS band spurs
 - High Immunity to TDMA (GSM/GPRS) burst noise
 - Multiple crystal frequencies supported
 - 2- and 3-wire control interfaces
- **Robust Operation**
 - -25^oC to +85^oC operation
 - ESD protection on all input and output pads

Typical Applications

- Cell Phones / PDAs / Smart Phones
- Portable Audio & Media Players
- GPS Personal Navigation Devices
- Automotive Accessories

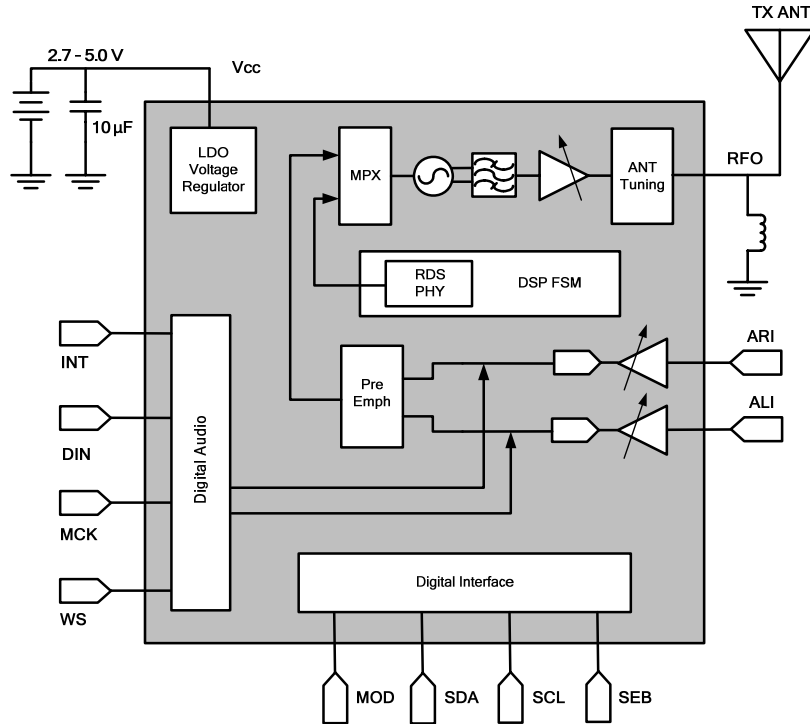

QN8007B Block Diagram

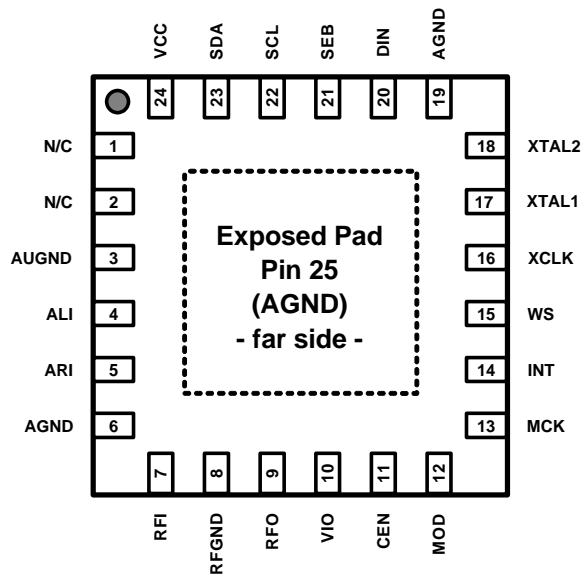

QN8007B Pin Out

CONTACT INFORMATION

Quintic Corporation (USA)
 3211 Scott Blvd, Suite 203
 Santa Clara, CA 95054
 Tel: +1 408 970-8808
 Fax: +1 408 970-8829
 Email: support@quinticcorp.com
 Web: www.quinticcorp.com

Quintic Microelectronics (China)
 Building 8 B-301A Tsinghua Science Park
 1st East Zhongguancun Rd, Haidian
 Beijing, China 100084
 Tel: +86 (10) 8215-1997
 Fax: +86 (10) 8215-1570
 Email: support@quinticcorp.com
 Web: www.quinticcorp.com

Quintic Microelectronics and Quintic are trademarks of Quintic Corporation. All Rights Reserved.