

High Performance Digital FM Transceiver for Portable Devices

General Description

The QN8006 is a high performance, low power, fully integrated single-chip stereo FM transceiver designed for cell phones, PMP/PNDs, and portable radios. It integrates both FM receiving and transmitting functions, auto-seek and clear channel scan, and antenna tuning to ease matching in real applications. Advanced digital architecture enables superior receiver sensitivity, crystal clear audio, unsurpassed spectral purity, ultra-low harmonic and spurious levels, and high immunity to TDMA burst noise.

With its small footprint, minimal external component count and multiple clock frequency support, the QN8006 is easy to integrate into a variety of small form-factor low power portable applications. An integrated voltage regulator enables direct connection to a battery and provides high PSRR for superior noise suppression. A low-power Standby mode extends battery life. ESD protection is on all pins. The QN8006 is fabricated in highly reliable CMOS technology.

Key Features

- **Worldwide FM Band Receive and Transmit**
 - 76 MHz ~ 108 MHz full band tuning in 50/100/200 kHz step sizes
 - 50/75 μ s pre-emphasis and de-emphasis
- **High Performance FM Receiver (FMR)**
 - Superior sensitivity: 1.4 μ V_{EMF}
 - High SNR: 66dB Stereo
 - Ultra Low THD: 0.03%
 - High interference rejection
 - Integrated adaptive noise cancellation (SNC, HCC, SM)
 - Auto channel seek
- **High Performance FM Transmitter (FMT)**
 - 66dB Stereo SNR, 0.03% THD
 - Maximum 121dB μ Vp RF output level with 42dB adjustable range
 - Integrated Clear Channel Scan
- **RDS/RBDS Transmit & Receive**
 - Supports US and European data service, including TMC (Traffic Messaging Channel)
- **Very Low Power Consumption**
 - 9.2mA (Transmit Mode), 17 mA (Receive Mode)
 - Integrated voltage regulator, direct connect to battery
 - Power saving IDLE and Standby modes
 - Low shutdown leakage current
- **Flexible Audio Interfaces**
 - Digital audio interface supports I²S and a variety of PCM data formats with 4 different data rates
 - Programmable analog audio input/output
 - Integrated audio AGC and soft clipping
- **Ease of Integration**
 - Small footprint, 4 x 4 x 0.85mm QFN24
 - Adaptive antenna tuning
 - Low cellular and GPS band spurs
 - High Immunity to TDMA (GSM/GPRS) burst noise
 - Multiple crystal frequencies supported
 - 2- and 3-wire control interfaces
- **Robust Operation**
 - -25^oC to +85^oC operation
 - ESD protection on all input and output pads

Typical Applications

- Cell Phones / PDAs / Smart Phones
- Portable Audio & Media Players
- GPS Personal Navigation Devices
- Automotive Accessories

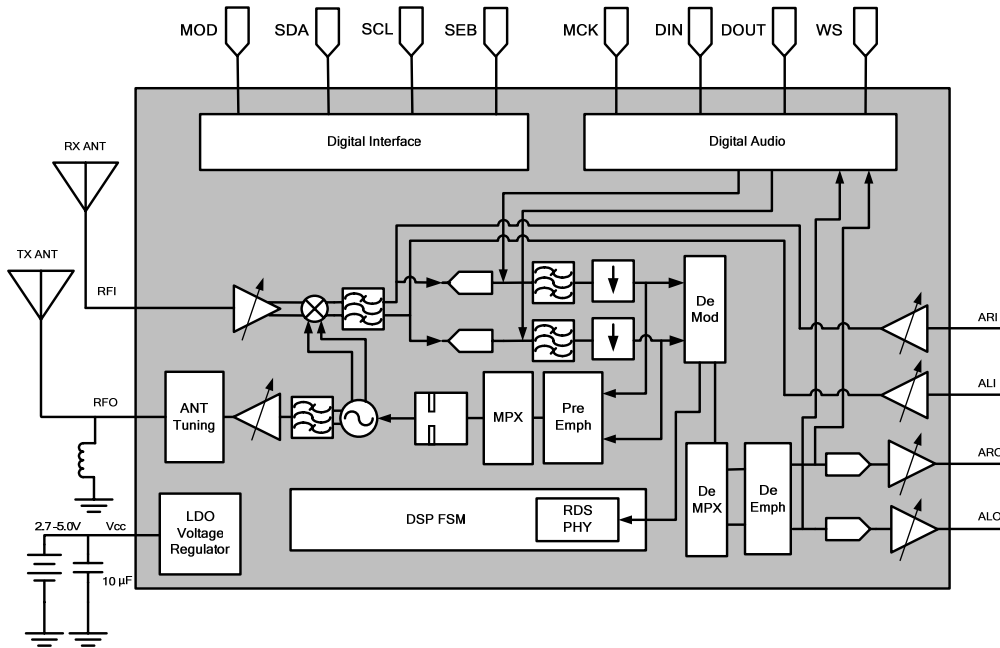

QN8006B Block Diagram

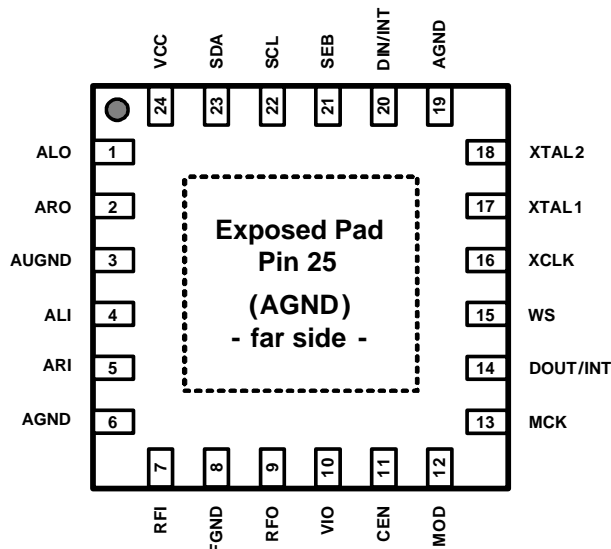

QN8006B Pin Out

CONTACT INFORMATION

Quintic Corporation (USA)
 3211 Scott Blvd, Suite 203
 Santa Clara, CA 95054
 Tel: +1 408 970-8808
 Fax: +1 408 970-8829
 Email: support@quinticcorp.com
 Web: www.quinticcorp.com

Quintic Microelectronics (China)
 Building 8 B-301A Tsinghua Science Park
 1st East Zhongguancun Rd, Haidian
 Beijing, China 100084
 Tel: +86 (10) 8215-1997
 Fax: +86 (10) 8215-1570
 Email: support@quinticcorp.com
 Web: www.quinticcorp.com

Quintic Microelectronics and Quintic are trademarks of Quintic Corporation. All Rights Reserved.